

## TELUX™

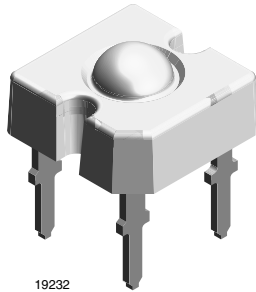

### FEATURES

- High luminous flux
- Supreme heat dissipation:  $R_{thJP}$  is 90 K/W
- High operating temperature:  
 $T_{amb} = -40\text{ °C to }+110\text{ °C}$
- Meets SAE and ECE color requirements for the automobile industry for color red
- Packed in tubes for automatic insertion
- Luminous flux, forward voltage and color categorized for each tube
- Small mechanical tolerances allow precise usage of external reflectors or lightguides
- Lead (Pb)-free device
- Component in accordance to RoHS 2002/95/EC and WEEE 2002/96/EC
- ESD-withstand voltage: up to 2 kV according to JESD22-A114-B
- Compatible with wave solder processes acc. to CECC 00802 and J-STD-020C
- Automotive qualified



### DESCRIPTION

The TELUX™ series is a clear, non diffused LED for applications where supreme luminous flux is required. It is designed in an industry standard 7.62 mm square package utilizing highly developed AlInGaP technology.

The supreme heat dissipation of TELUX™ allows applications at high ambient temperatures.

All packing units are binned for luminous flux, forward voltage and color to achieve the most homogenous light appearance in application.

SAE and ECE color requirements for automobile application are available for color red.

### APPLICATIONS

- Exterior lighting
- Dashboard illumination
- Tail-, stop- and turn signals of motor vehicles
- Replaces small incandescent lamps
- Traffic signals and signs

### PRODUCT GROUP AND PACKAGE DATA

- Product group: LED
- Package: TELUX™
- Product series: power
- Angle of half intensity:  $\pm 45^\circ$

PARTS TABLE		
PART	COLOR, LUMINOUS FLUX	TECHNOLOGY
TLWR8900	Red, $\phi_v = 3000\text{ mlm (typ.)}$	AlInGaP on GaAs
TLWY8900	Yellow, $\phi_v = 3000\text{ mlm (typ.)}$	AlInGaP on GaAs

<b>ABSOLUTE MAXIMUM RATINGS<sup>1)</sup> TLWR8900, TLWY8900</b>				
PARAMETER	TEST CONDITION	SYMBOL	VALUE	UNIT
Reverse voltage <sup>2)</sup>	$I_R = 100 \mu\text{A}$	$V_R$	10	V
DC Forward current	$T_{\text{amb}} \leq 85 \text{ }^\circ\text{C}$	$I_F$	70	mA
Surge forward current	$t_p \leq 10 \mu\text{s}$	$I_{\text{FSM}}$	1	A
Power dissipation		$P_V$	187	mW
Junction temperature		$T_j$	125	$^\circ\text{C}$
Operating temperature range		$T_{\text{amb}}$	- 40 to + 110	$^\circ\text{C}$
Storage temperature range		$T_{\text{stg}}$	- 55 to + 110	$^\circ\text{C}$
Soldering temperature	$t \leq 5 \text{ s}$ , 1.5 mm from body preheat temperature 100 $^\circ\text{C}/30 \text{ s}$	$T_{\text{sd}}$	260	$^\circ\text{C}$
Thermal resistance junction/ambient	with cathode heatsink of 70 mm <sup>2</sup>	$R_{\text{thJA}}$	200	K/W
Thermal resistance junction/pin		$R_{\text{thJP}}$	90	K/W

Note:

1)  $T_{\text{amb}} = 25 \text{ }^\circ\text{C}$ , unless otherwise specified

2) Driving the LED in reverse direction is suitable for a short term application

<b>OPTICAL AND ELECTRICAL CHARACTERISTICS<sup>1)</sup> TLWR8900, RED</b>						
PARAMETER	TEST CONDITION	SYMBOL	MIN	TYP.	MAX	UNIT
Total flux	$I_F = 70 \text{ mA}$ , $R_{\text{thJA}} = 200 \text{ }^\circ\text{K/W}$	$\phi_V$	2000	3000		mlm
Luminous intensity/total flux	$I_F = 70 \text{ mA}$ , $R_{\text{thJA}} = 200 \text{ }^\circ\text{K/W}$	$I_V/\phi_V$		0.7		mcd/mlm
Dominant wavelength	$I_F = 70 \text{ mA}$ , $R_{\text{thJA}} = 200 \text{ }^\circ\text{K/W}$	$\lambda_d$	611	615	634	nm
Peak wavelength	$I_F = 70 \text{ mA}$ , $R_{\text{thJA}} = 200 \text{ }^\circ\text{K/W}$	$\lambda_p$		624		nm
Angle of half intensity	$I_F = 70 \text{ mA}$ , $R_{\text{thJA}} = 200 \text{ }^\circ\text{K/W}$	$\varphi$		$\pm 45$		deg
Total included angle	90 % of total flux captured	$\varphi_{0.9V}$		75		deg
Forward voltage	$I_F = 70 \text{ mA}$ , $R_{\text{thJA}} = 200 \text{ }^\circ\text{K/W}$	$V_F$	2.0	2.2	2.7	V
Reverse voltage	$I_R = 10 \mu\text{A}$	$V_R$	10	20		V
Junction capacitance	$V_R = 0$ , $f = 1 \text{ MHz}$	$C_j$		17		pF

Note:

1)  $T_{\text{amb}} = 25 \text{ }^\circ\text{C}$ , unless otherwise specified

<b>OPTICAL AND ELECTRICAL CHARACTERISTICS<sup>1)</sup> TLWY8900, YELLOW</b>						
PARAMETER	TEST CONDITION	SYMBOL	MIN	TYP.	MAX	UNIT
Total flux	$I_F = 70 \text{ mA}$ , $R_{\text{thJA}} = 200 \text{ }^\circ\text{K/W}$	$\phi_V$	2000	3000		mlm
Luminous intensity/total flux	$I_F = 70 \text{ mA}$ , $R_{\text{thJA}} = 200 \text{ }^\circ\text{K/W}$	$I_V/\phi_V$		0.7		mcd/mlm
Dominant wavelength	$I_F = 70 \text{ mA}$ , $R_{\text{thJA}} = 200 \text{ }^\circ\text{K/W}$	$\lambda_d$	585	590	597	nm
Peak wavelength	$I_F = 70 \text{ mA}$ , $R_{\text{thJA}} = 200 \text{ }^\circ\text{K/W}$	$\lambda_p$		594		nm
Angle of half intensity	$I_F = 70 \text{ mA}$ , $R_{\text{thJA}} = 200 \text{ }^\circ\text{K/W}$	$\varphi$		$\pm 45$		deg
Total included angle	90 % of total flux captured	$\varphi_{0.9V}$		75		deg
Forward voltage	$I_F = 70 \text{ mA}$ , $R_{\text{thJA}} = 200 \text{ }^\circ\text{K/W}$	$V_F$	1.83	2.1	2.7	V
Reverse voltage	$I_R = 10 \mu\text{A}$	$V_R$	10	15		V
Junction capacitance	$V_R = 0$ , $f = 1 \text{ MHz}$	$C_j$		17		pF

Note:

1)  $T_{\text{amb}} = 25 \text{ }^\circ\text{C}$ , unless otherwise specified

<b>LUMINOUS FLUX CLASSIFICATION</b>		
GROUP	LUMINOUS FLUX (MLM)	
	MIN	MAX
D	2000	3000
E	2500	3600
F	3000	4200
G	3500	4800
H	4000	6100
I	5000	7300
K	6000	9700
L	7000	12200
M	8000	15000

Note:

Luminous flux is tested at a current pulse duration of 25 ms and an accuracy of  $\pm 11\%$ .

The above type numbers represent the order groups which include only a few brightness groups. Only one group will be shipped on each tube (there will be no mixing of two groups on each tube).

In order to ensure availability, single brightness groups will be not orderable.

In a similar manner for colors where wavelength groups are measured and binned, single wavelength groups will be shipped in any one tube.

In order to ensure availability, single wavelength groups will not be orderable.

### TYPICAL CHARACTERISTICS

$T_{amb} = 25\text{ }^{\circ}\text{C}$ , unless otherwise specified

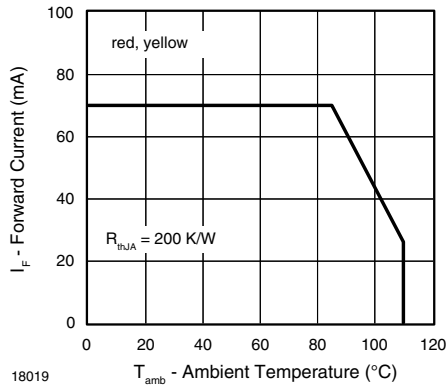

Figure 1. Forward Current vs. Ambient Temperature

<b>COLOR CLASSIFICATION</b>				
GROUP	DOM. WAVELENGTH (NM)			
	YELLOW		RED	
	MIN.	MAX.	MIN.	MAX.
0	585	588		
1	587	591	611	618
2	589	594	614	622
3	592	597	616	634

Note:

Wavelengths are tested at a current pulse duration of 25 ms and an accuracy of  $\pm 1\text{ nm}$ .

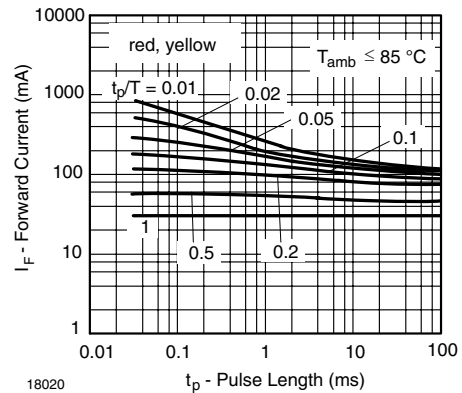

Figure 2. Forward Current vs. Pulse Length

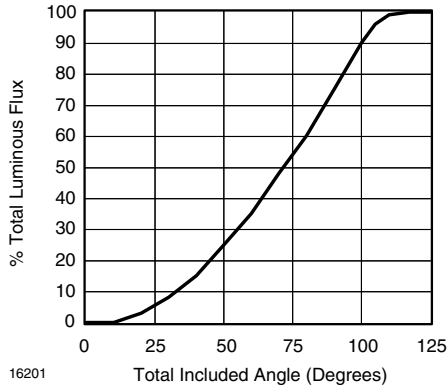
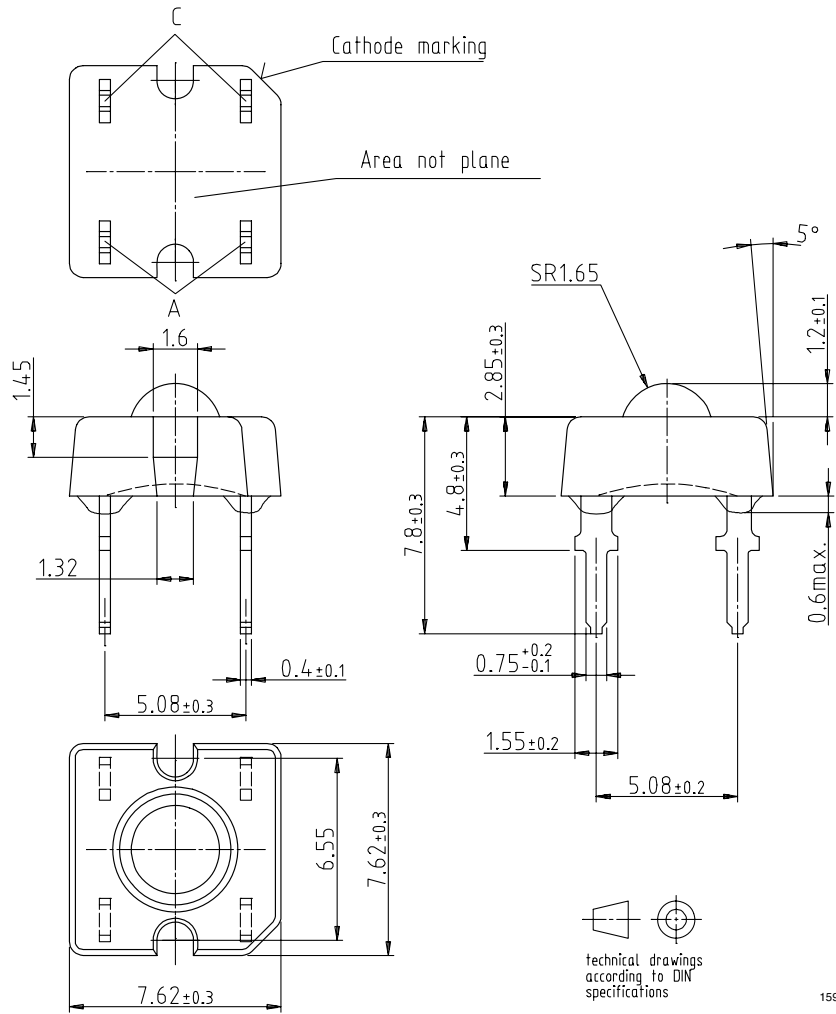

Figure 15. Percentage Total Luminous Flux vs. Total Included Angle for 90° Emission Angle

**PACKAGE DIMENSIONS** in millimeters



15984

**TUBE WITH BAR CODE LABEL** Dimensions in millimeters

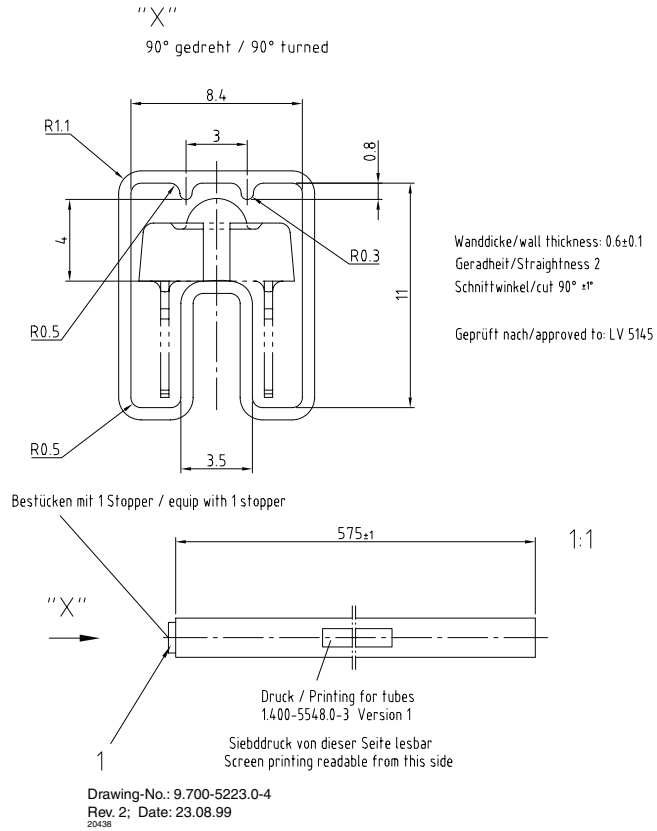

Figure 16. Drawing Proportions not scaled